

Powerline QC

500A & 750A Single Pole Power
Connectors



Index

Introduction	3
Sandwich Contact Retention System	4
Integrating Sliding Locking Pin	5
Slide Locking Retention System	6
Part Number Configuration	7
Powerline Cable Connectors	8
Part Number Configuration	9
Powerline Panel Connectors	10
Powerline 18 Degree Angled Bracket	11
Environmental Locking Caps / Standard Dust Caps	12
Powerline Cable Extensions	13
Cable Connectors Dimensions	14
Panel Connectors Dimensions	15-16
Definitions and Terminology	17
Connector Parameters	18
Connector Rated Current	19
Reference Data for Cable Selection	20
Assembly Instruction Guides	21-26
Disassembly Instruction Guide	27-28
Integrated Sliding Locking Pin / Fixed Locking Pin	29
Guide for Changing Locking Pin	30-31

Introduction



Background

Keyed “L” slot single pole connectors have become widely adopted in a diverse range of applications and industries.

One of the main features of early designs was the mechanical keying of the connectors to prevent possible connection errors; i.e., a Phase Line cannot be connected into Earth Line, etc.

It was evident that several enhancements to existing designs were possible to further improve the product but at the same time remaining intermateable.

Typical Applications

- Power Distribution
- Utilities
- Electric Vehicles
- Railway Equipment
- Mobile Generators
- Loadbanks
- Back-up Power Systems

Powerline Features

- 500 Mating Cycles minimum
- Intermateable with other versions
- IP2X Finger Protected contacts
- IP68 sealed when mated
- Remote tool required to release mated connectors
- For use with Electrical Power Cables
- Heavy Duty Hand Grips
- Clip retained contacts
- No Dowel/Cotter pin required
- Cable sizes from 25mm² to 300mm²
- Facilitate cables up to 37mm Ø
- High Impact Insulators
- Harmonised Colour Coding
- CE Compliant
- EN/ESI compliant Creepage and Clearance distances
- Multi-louver contact system
- Mechanically keyed to prevent connection errors
- Permanent Marking
- Set Screw and Crimp contact versions
- UL94 VO Flame Retardant
- Field Assembly and Repair
- No special tools required
- Daisy Chain hook up system

Sandwich Contact Retention System

Ten 47 introduce a unique two piece Single Pole 500 and 750 amp connector compatible with all industry standard brands. Building on our proven original Powerline connector series with familiar safety features such as mechanically keyed, colour coded insulators and finger proof contacts, the Ten 47 “Powerline QC” range offers many enhancements over existing designs.

New innovations include centred contact alignment, low connector mating forces, improved mechanical insulator strength, IP protected retained louvre band and environmental sealing to IP68.

In addition our proprietary sandwich contact retention system within a two piece insulator body allows replaceable front ends and eliminates the need for a “Cotter/dowel pin” common on similar products ensuring reduced assembly and maintenance down times.



Integrated Sliding Locking Pin

Line drain connectors are supplied with a spring loaded integral secondary locking release key allowing the operator a quick and easy un-mating process.

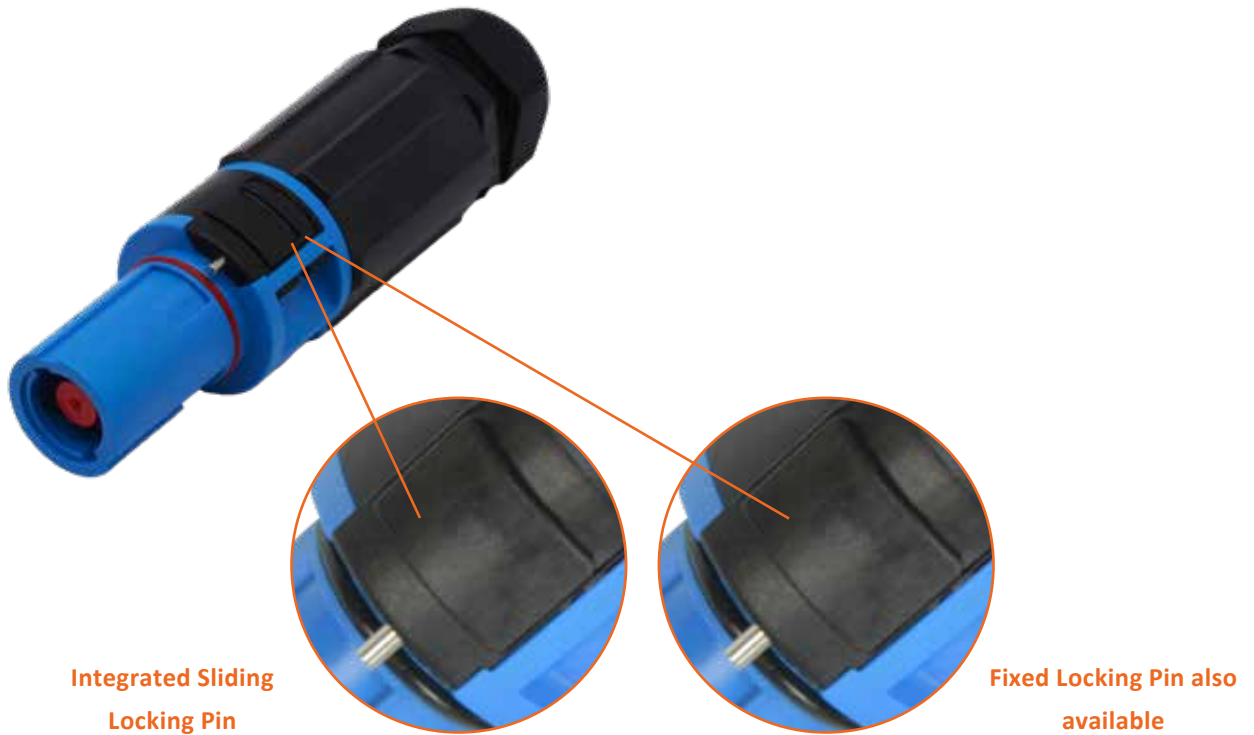

Most versions of this connector format have relied upon the electrical contact being retained within the insulator by means of a plastic dowel/cotter pin. These pins are forced through a mating hole in the Insulator and contact and any re-use of the same pin may adversely affect the IP sealing of the connectors.

- The contacts are inserted from the rear and locked into place within a two piece insulator which is the first of its kind allowing the user to replace front ends should damage occur. One piece insulators on existing brands are particularly susceptible to damage in this area.
- The sandwich contact retention system within the two piece insulator body eliminates the need for a “Cotter/dowel pin” common on similar products, improving environmental sealing and reducing assembly and maintenance down times and costs.
- Ten 47 “Powerline” contacts are retained by a novel sandwich design that can withstand the equivalent weight of 100 metres of 150mm² cable.
- Improved mechanical insulator strength, abrasion resistance and a higher temperature rating.
- Line drain connectors are supplied with a spring loaded integral secondary locking release key allowing the operator a quick and easy un-mating process.
- Our new retained louvre band system (intellectual property protected) solves a common fault on existing brands which tend to loosen over prolonged use resulting in electrical faults, while remaining replaceable if damaged.

Slide Locking Retention System

Below, step by step images showing the Slide Locking Retention System in use.

Step 1

Cable connectors mated and held in place via the secondary locking pin.



Step 2

Release integrated sliding release key.



Step 3

Twist to disengage key way.



Step 4

Uncouple connectors.
Warning – Do not uncouple under load.



Part Number Configuration for Line Connectors

(120mm² Set Screw with 21-26mm Cable OD Gland)

Connector Style	
Cable Connector	CS
Cable Plug (Sliding Lock)	CP
Cable Plug (Fixed Locking Pin)	CPL

Key Position	
Earth	E
Neutral	N
Line 1	L1
Line 2	L2
Line 3	L3

Insulator Colour	
Green	GRN
Blue	BLU
Brown	BRN
Black	BLK
Grey	GRY
Red	RED
Yellow	YEL
White	WHT

Contact Termination	
Set Screw for up to 150mm ²	S
Crimp Contact for 185, 240, 300mm ²	C

Cable Conductor Size	
25mm ²	25
35mm ²	35
50mm ²	50
70mm ²	70
95mm ²	95
120mm²	120
150mm ²	150
185mm ²	185
240mm ²	240
300mm ²	300

Cable External Diameter	
15mm - 21mm	S
21mm - 26mm	M
26mm - 32mm	OS
33mm - 38mm	M50

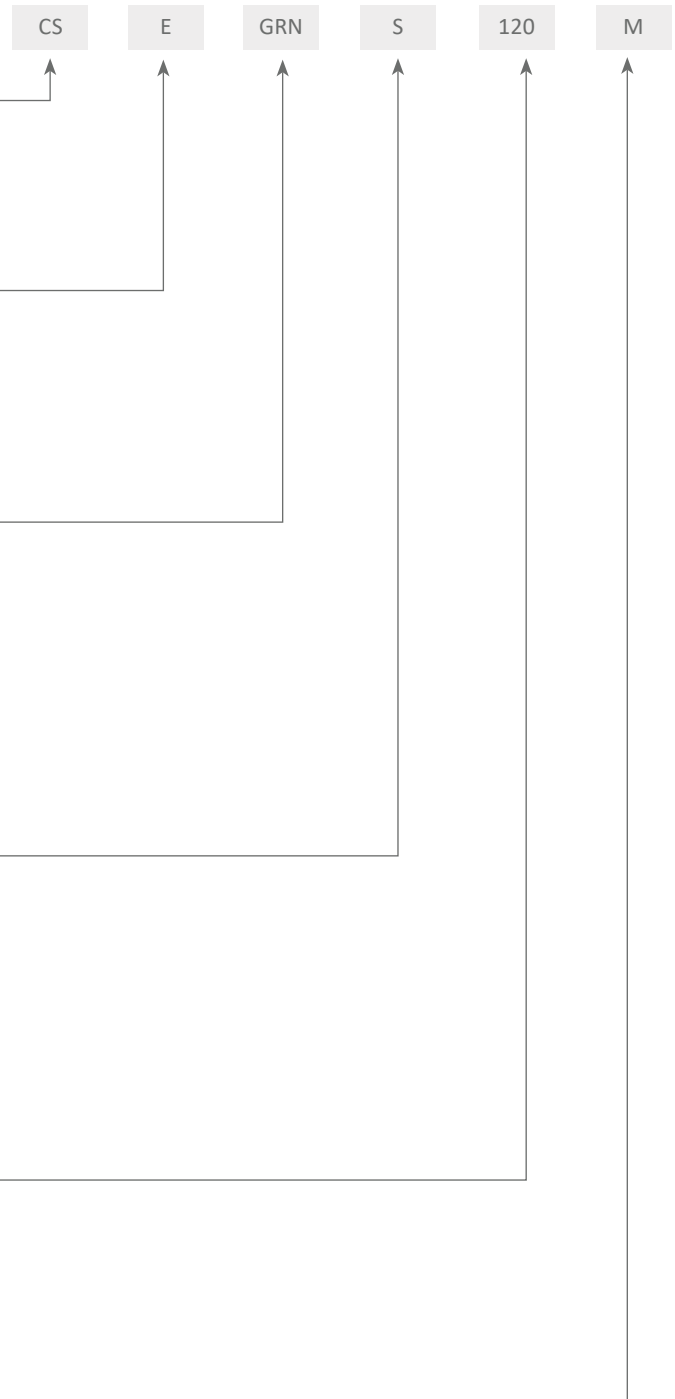

COLOUR CODING	Earth	Neutral	Line 1	Line 2	Line 3
UK & Europe	Green	Blue	Brown	Black	Grey
Commonwealth	Green	Black	Red	Yellow	Blue
USA	Green	White	Black	Red	Blue
Australia	Green	Black	Red	White	Blue

Powerline Cable Connectors

Cable Connector (Line Source) - Style "CS"

Cable Sockets are typically used as the Live or Supply side of the circuit and utilise a Solid Insulated contact tip to provide IP2X Finger Protection when unmated. "CS" Connectors incorporate a slot that engages with the Locking Pin on both the mating Panel Inlet and Cable Plug connectors.



Cable Plug (Line Drain) - Style "CP"

"CP" Connectors utilise a spring-mounted contact with a Double Insulated Sleeve that provides IP2X Finger Protection when unmated. The "CP" contact depresses the spring and sleeves to obtain Electrical connection. When unmated, they return automatically to the IP2X position.

A Locking Pin engages with the slot on both the Panel Socket and Cable Socket when mated. The cable plug has an optional Slide release pin so no tool is required.



- When disconnected all connectors are IP2X Protected.
- In Line Connectors are supplied as standard with Metric Cable Glands.
- Connectors seal to IP68 when mated.
- Once mated, the connectors are separated by using a remote unlocking key, or the sliding pin on the cable plug.
- Panel connectors can be Front or Rear mounted on equipment.
- All connectors are mechanically keyed and individually colour coded to help prevent any possible cross connection errors. (See page 7 for key positions and colours.)

Part Number Configuration for Panel Connectors

(M12 Threaded Post for up to 500 Amps)

Connector Style

Panel Socket*	PS
Panel Inlet*	PP

Key Position

Earth	E
Neutral	N
Line 1	L1
Line 2	L2
Line 3	L3

Insulator Colour

Green	GRN
Blue	BLU
Brown	BRN
Black	BLK
Grey	GRY
Red	RED
Yellow	YEL
White	WHT

Contact Termination

M12 Threaded Post for up to 500 Amps	M5
M12 Female Thread 500 Amps	F5
M12 Threaded Post for up to 750 Amps	M7
M12 Female Thread 750 Amps	F7

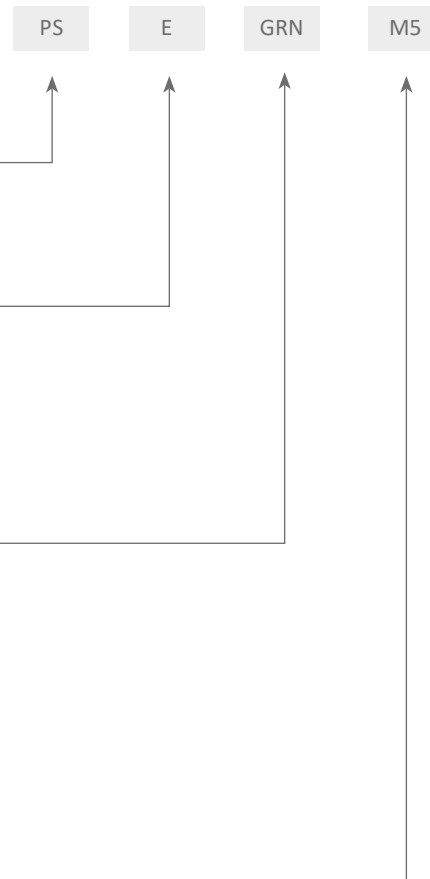

* If you require a gasket please contact sales office.
 For **modification codes** contact sales office.

COLOUR CODING	Earth	Neutral	Line 1	Line 2	Line 3
UK & Europa	Green	Blue	Brown	Black	Grey
Commonwealth	Green	Black	Red	Yellow	Blue
USA	Green	White	Black	Red	Blue
Australia	Green	Black	Red	White	Blue

Powerline Panel Connectors

Panel Socket (Panel Source) - Style "PS"

Panel Socket Connectors are typically used as the Live or Supply side of the circuit and utilise a Solid Insulated contact tip to provide IP2X Finger Protection when unmated. "PS" Connectors incorporate a slot that engages with the Locking Pin on both the mating Panel Plug and Cable Plug connectors.



M12 Threaded Post



Female Threaded version

Panel Plug (Panel Drain) - Style "PP"

"PP" Connectors utilise a spring-mounted contact with a Double Insulated Sleeve that provides IP2X Finger Protection when unmated. The "CS" contact depresses the spring and sleeves to obtain Electrical connection. When unmated, they return automatically to the IP2X position.

A Locking Pin engages with the slot on both the Panel Socket and Cable Socket when mated.



M12 Threaded Post



Female Threaded version

Gaskets

Gaskets are available for Powerline Panel Connectors - please contact our sales team for pricing.

Powerline 18 Degree Angled Bracket

The Powerline 18 degree angled Bracket kit enables mounting any standard panel connector at angle to save space and reduce strain from the weight of the mating cable extensions. Installing panel connectors at an angle also helps incoming cables hang more ergonomically for easier connecting and disconnecting.

Kit contents:

- 4 x M5 25mm screws (plus washers)
- 1 x Rubber Gasket
- 1 x 18 Degree Angled Bracket with M5 copper alloy threaded insert



Shown with Panel Socket (Panel Source) Style "PS"



Shown with Panel Plug (Panel Drain) Style "PP"



Shown with Panel Plug (Panel Drain) Style "PP" (REAR VIEW)

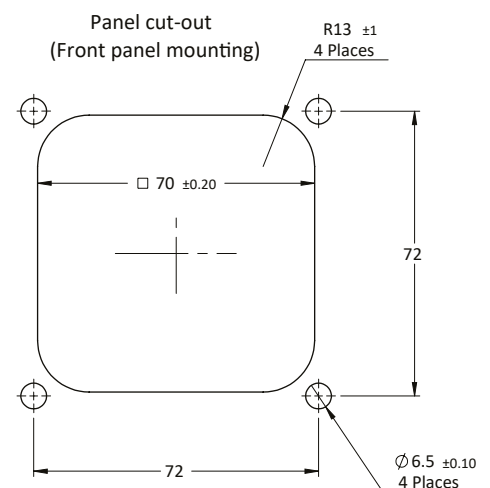
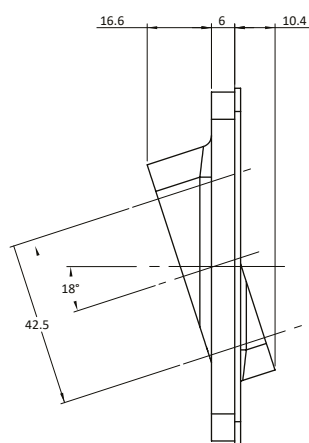
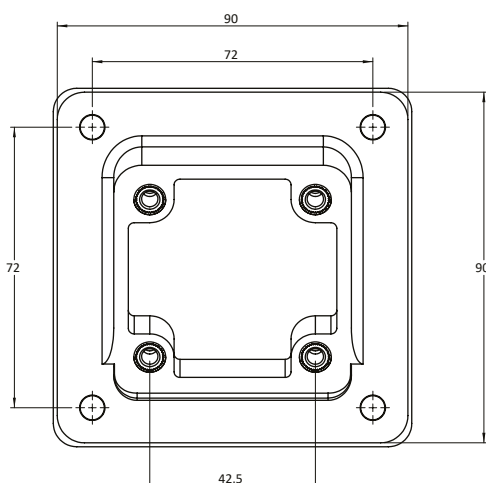

Environmental Locking Caps

Environmental caps offer increased protection.

Environmental caps are manufactured in high impact Black Acetal with retention line of 1.5mm thick nylon thread crimped with tinned copper ferrules. In addition to the features of the standard dust cap, they offer IP68 rated sealing and made to fit into keyway to turn and hold in place.



ENV-CAP-PS



ENV-CAP-PP



ENV-CAP-CS

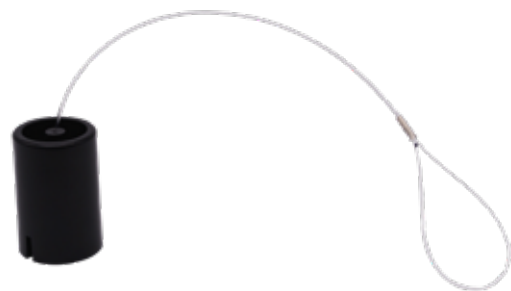

ENV-CAP-CP

Standard Dust Caps

CAP-CS CAP-CP CAP-PS CAP-PP



Plastic Push/Pull caps are fitted with retention line of 1.5mm thick nylon thread crimped with tinned copper ferrules.

Ideal for indoor or waterproofed cabinets to protect against dust/particle ingress.

Powerline Cable Extensions

In addition to our Powerlock compatible Powerline Single Pole connectors, we can supply premade cable drain to source or lugged cable extensions to custom lengths and specifications. Our extensions are built using premium grade TITANEX® heavy duty flexible rubber HO7 RNF cable from 25mm² to 300mm² and can be supplied with colour coded or pre-printed heatshrink for identification. With bulk stock to build of connectors and cables we provide a fast turnaround service for quick and reliable delivery.

Part Number Configuration

PLA - E - 120 - 10 - M12 - H07

Assembly Configuration	
Cable Connector to Cable Connector	CCA
Cable Connector to Cable Plug	CPA
Cable Connector to LUG	CLA
Cable Plug to Cable Plug	PPA
Cable Plug to LUG	PLA
LUG to LUG	LLA

Key Position	
Earth	E
Neutral	N
Line 1	L1
Line 2	L2
Line 3	L3

Cable Size*	as required in mm ²
* 25 - 300mm ² cable supplied with our Powerline QC connectors	

Assembly Length	as required in metres
-----------------	-----------------------

LUG Bolt Size (if applicable)	
Hole Size	M10
Hole Size	M12

Cable Type**
** Other cable types are available, please consult sales

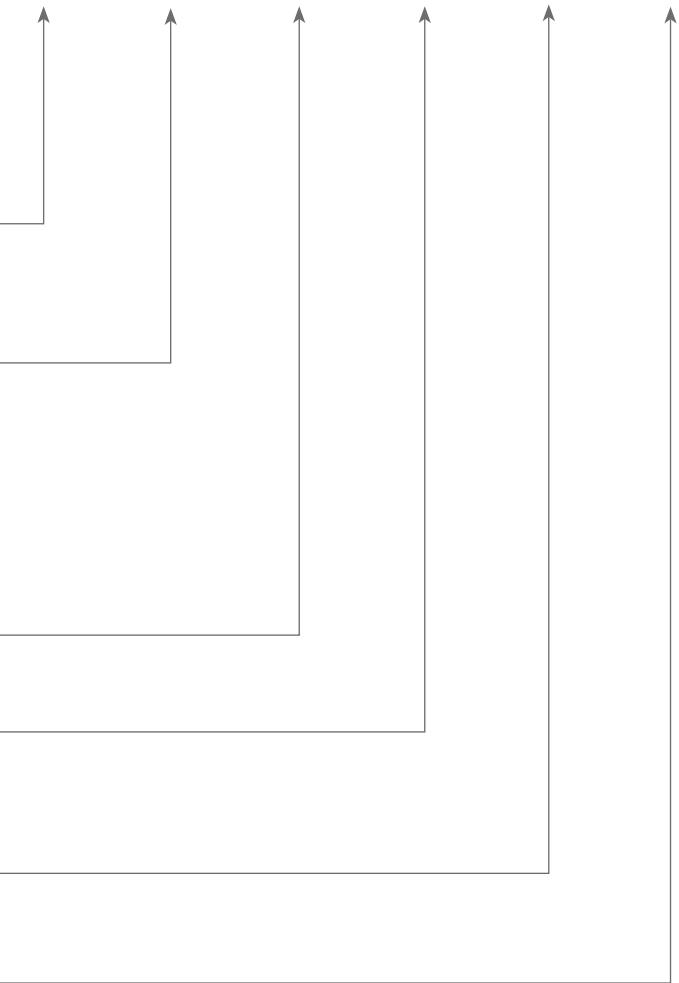

Cable Connectors Dimensions

Cable Plug

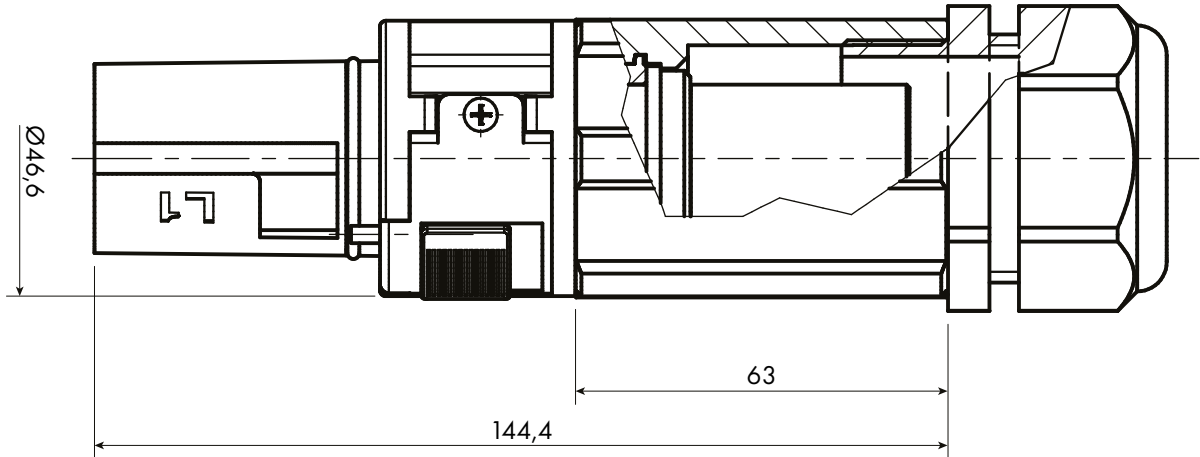

Cable Socket

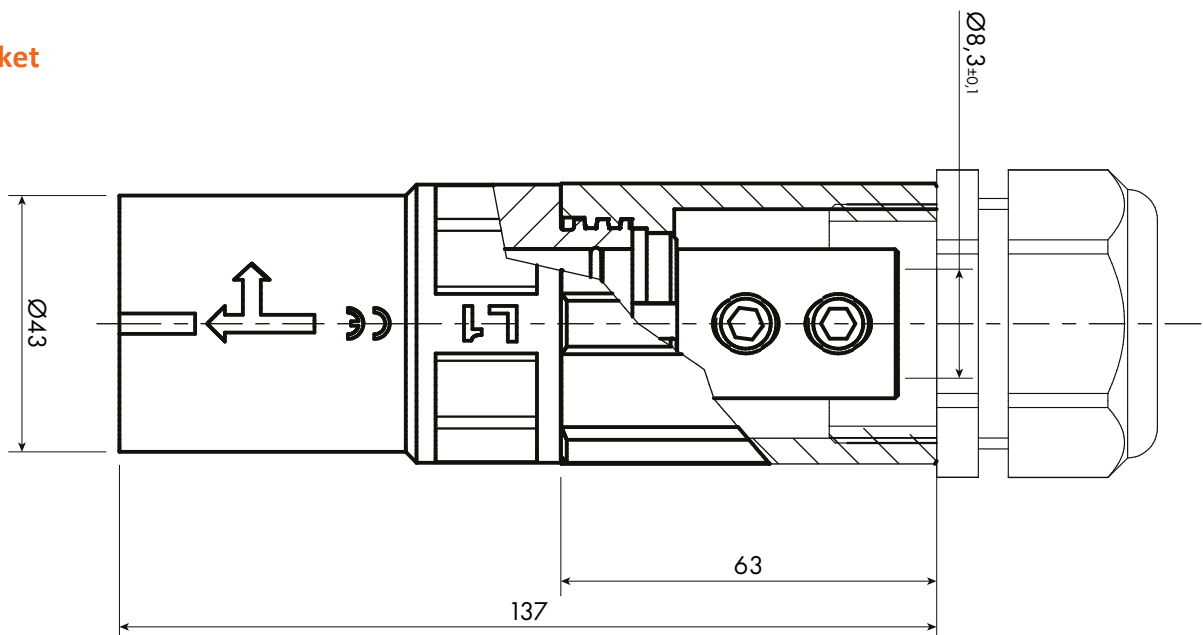

Panel Connectors Dimensions

Panel Socket – M12 Threaded Post

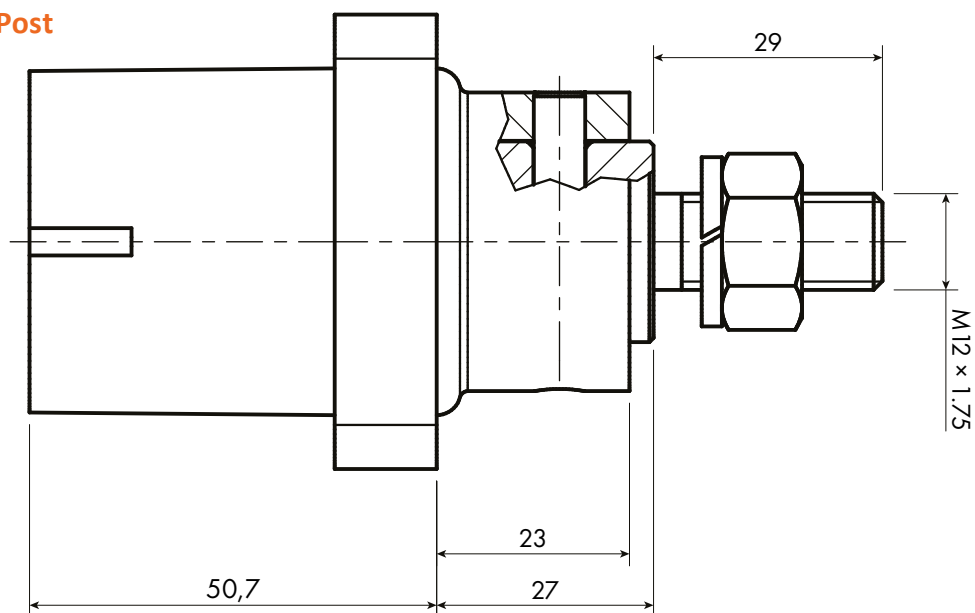

Panel Socket – Female Thread version

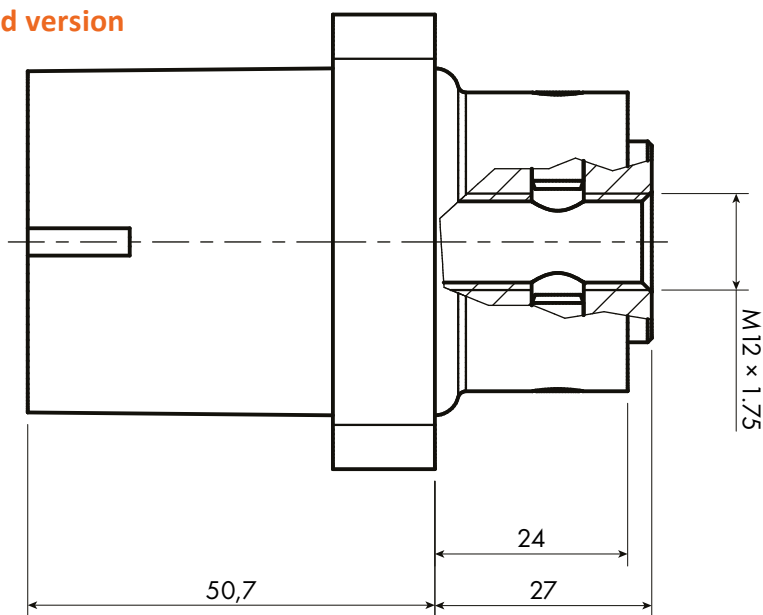

Cut Out Dimensions

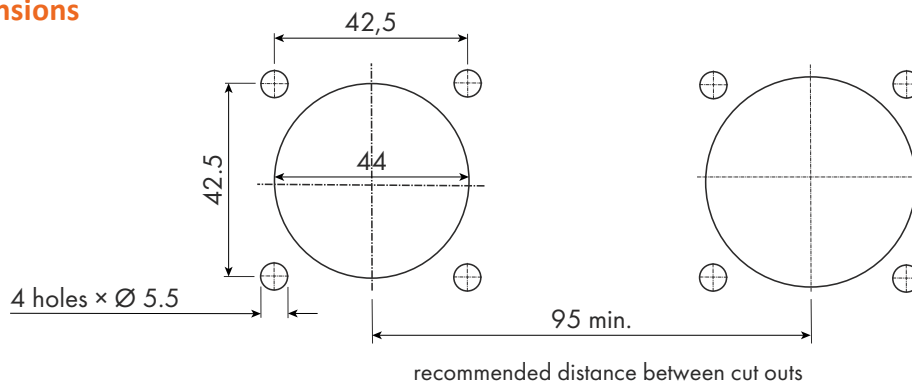

Panel Connectors Dimensions

Panel Plug – M12 Threaded Post

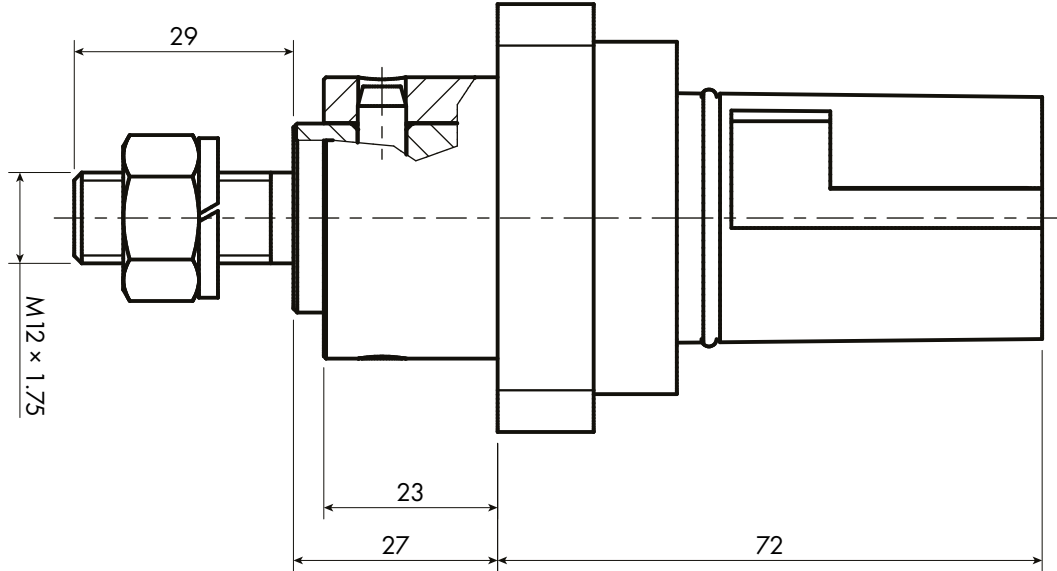

Panel Plug – Female Thread version

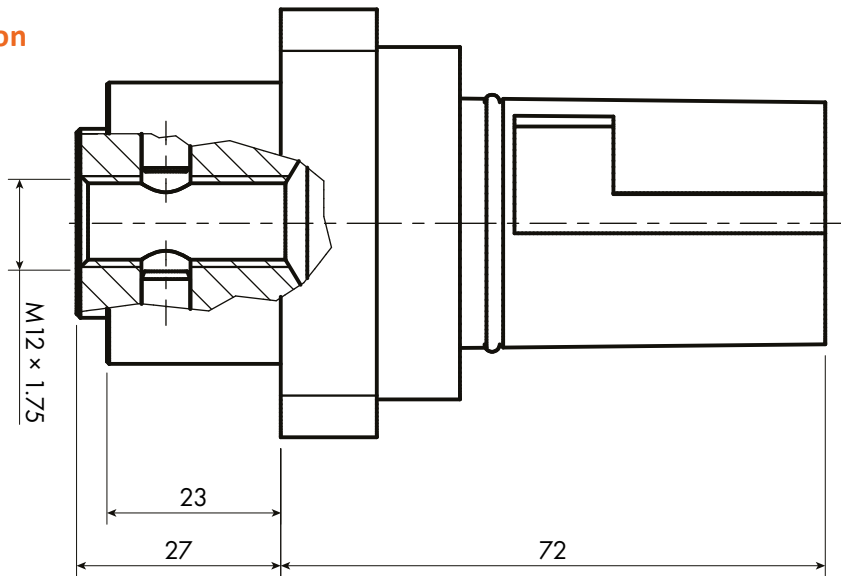

Cut Out Dimensions

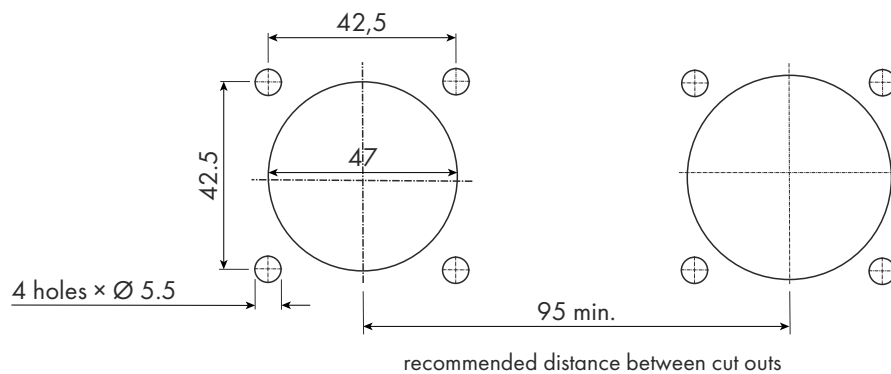

Definitions and Terminology

Rated Current

The current rating of the connector is determined by the conductor size and type utilised. Values are taken from IEE wiring regulations BS7671 Table 4F1A Reference method 12 (cables in Free Air). The quoted values relate to non-armoured Single core, copper stranded cable with Rubber insulation and an operating temperature of 85°C. The de-rated values for ambient temperature are taken from Table 4H2A.

Rated Voltage

The determined voltage of a connector from which the related operating characteristics are defined.

Contact Resistance

The resistance occurring at the point of two contact areas. Its value is calculated with the measured voltage drop and the rated current.

Test Voltage

The voltage the connector will withstand without breakdown or flashover under test conditions.

Surge Current

The current the connector will withstand during a short time surge or current spike. Duration 10msecs.

Ingress Protection

Level of resistance to dust and water ingress according to EN60529. When mated, Powerline connectors meet the requirements of IP68, submersible in water and closed to entry of foreign objects.

Creepage

The shortest distance along the surface of the Insulating material between two conductive parts. This is also a function of the properties of the insulating material.

Clearance

The shortest distance in air for arcing potential between two conductive parts.

Mating Cycles

The minimum number of continuous mating operations the connectors will withstand without damage to their operation or safety. The values assume normal usage.

CE Cable Glands

In December 1999, European standard EN50262 (metric glands) replaced the withdrawn standard DIN46320 (PG glands). The transition period for granting certification marks for PG glands ended on 1st March 2001. In order to comply with CE Certification requirements, Powerline utilises metric glands compliant with current legislation and specifications.

Set Screw Termination

Two threaded set screws at the cable entry point into the contact. The screws are tightened to compress a copper sleeve(s) fitted around the strands of the cable conductor. The standard contact is supplied with a sleeve suitable for 120/150mm² CSA. When used with smaller cable sizes, additional sleeves are required to suit the cable size. The contacts are Silver Plated Copper Alloy.

Crimp Termination

Compression termination. The contacts are Silver Plated Oxygen Free high conductivity Copper.

Fixed Locking

Once mated, the connectors are locked together via a metal pin. Connectors can be unlocked via the integrated locking release key. This version provides additional safety where unsupervised or public access to live equipment may be possible.

Harmonised Colour Coding

On 31st March 2004, the IEE published Amendment No. 2 to BS7671: 2001 (IEE Wiring Regulations). This amendment specifies new cable core colours for Electrical installations in the UK. These "Harmonised" colours bring the UK more closely in line with practice in mainland Europe. Electrical installation work commencing after 31st March 2004 may use harmonised colours or the pre-existing colours, but not both. Work commencing after 31st March 2006 will be required to comply with harmonised colours and must not use old colours.

Powerline Series

New Harmonised Colour Codes and Marking for Single and Three-Phase applications.

Slide Locking

A version is available for the cable plug where a slide pin is used to allow unlocking without a remote key.

Function	Alphanumeric	Colour
Phase of single phase circuit	L	Brown
Neutral of single or three-phase circuit	N	Blue
Phase 1 of three-phase a.c. circuit	1	Brown
Phase 2 of three-phase a.c. circuit	2	Black
Phase 3 of three-phase a.c. circuit	3	Grey

Connector Parameters

Technical Parameter	Value
CS-*_*_*_*-S150-S weight	0.54kg
CS-*_*_*_*-S150-M weight	0.54kg
CS-*_*_*_*-S150-OS weight	0.57kg
CS-*_*_*_*-C185-OS weight	0.61kg
CS-*_*_*_*-C240-OS weight	0.62kg
CS-*_*_*_*-C300-OS weight	0.62kg
CP-*_*_*_*-S150-S weight	0.44kg
CP-*_*_*_*-S150-M weight	0.44kg
CP-*_*_*_*-S150-OS weight	0.47kg
CP-*_*_*_*-S185-OS weight	0.51kg
CP-*_*_*_*-S240-OS weight	0.52kg
CP-*_*_*_*-S300-OS weight	0.52kg
PS-*_*_*_*-M5 weight	0.33kg
PP-*_*_*_*-M5 weight	0.31kg
PS-*_*_*_*-M7 weight	0.35kg
PP-*_*_*_*-M7 weight	0.33kg
PS-*_*_*_*-F5 weight	0.27kg
PP-*_*_*_*-F5 weight	0.25kg
PS-*_*_*_*-F7 weight	0.29kg
PP-*_*_*_*-F7 weight	0.27kg
Set Screw Contact Tightening Torque	12Nm
Panel Contact Tightening Torque	25Nm max
Cable Gland Tightening Torque	13Nm
Minimum Mating Cycles	500
Contact Retention in Insulator	2.5kN Axial Load
Flammability	UL94 V0
Environmental Sealing (when mated)	IP68
Rated Voltage to Earth	2000V AC
Minimum Flashover (EN60309-1)	6.8kV AC – 1 minute
Minimum Insulation Resistance	5Gohms @ 500v
Operating Voltage	1000V AC or DC
Test Voltage (Mated Condition)	5kV – 1 minute @ 50Hz
Contact Resistance	<5mohms
Short Circuit Current – 1 second	16kA
Short Circuit Current – 3 seconds	12kA
Surge Current (DIN VDE 0102/1.90)	62kA – 10mseconds
Creepage Distance	>25mm
Clearance Distance	>25mm
Temperature Range	-30°C / +125°C

Connector Rated Current

Connector Style	Part Number	Current (Amps)	Minimum Cable c.s.a. for Rated Current (in free air)	Contact Termination
Panel Socket	PS-*_*_*_*-M5	495	150mm ²	M12 Thread
Panel Inlet	PP-*_*_*_*-M5	495	150mm ²	M12 Thread
Panel Socket	PS-*_*_*_*-M7	750	300mm ²	M12 Thread
Panel Inlet	PP-*_*_*_*-M7	750	300mm ²	M12 Thread
Panel Socket	PS-*_*_*_*-F5	495	150mm ²	M12 Thread
Panel Inlet	PP-*_*_*_*-F5	495	150mm ²	M12 Thread
Panel Socket	PS-*_*_*_*-F7	750	300mm ²	M12 Thread
Panel Inlet	PP-*_*_*_*-F7	750	300mm ²	M12 Thread
Cable Connector	CS-*_*_*_*-S25-*	154	25mm ²	Set Screw
Cable Connector	CS-*_*_*_*-S35-*	192	35mm ²	Set Screw
Cable Connector	CS-*_*_*_*-S50-*	235	50mm ²	Set Screw
Cable Connector	CS-*_*_*_*-S70-*	303	70mm ²	Set Screw
Cable Connector	CS-*_*_*_*-S95-*	370	95mm ²	Set Screw
Cable Connector	CS-*_*_*_*-S120-*	431	120mm ²	Set Screw
Cable Connector	CS-*_*_*_*-S150-*	495	150mm ²	Set Screw
Cable Connector	CS-*_*_*_*-S185-*	564	185mm ²	Crimped Contact
Cable Connector	CS-*_*_*_*-S240-*	673	240mm ²	Crimped Contact
Cable Connector	CS-*_*_*_*-S300-*	773	300mm ²	Crimped Contact
Cable Plug	CP*_*_*_*-S25-*	154	25mm ²	Set Screw
Cable Plug	CP*_*_*_*-S35-*	192	35mm ²	Set Screw
Cable Plug	CP*_*_*_*-S50-*	235	50mm ²	Set Screw
Cable Plug	CP*_*_*_*-S70-*	303	70mm ²	Set Screw
Cable Plug	CP*_*_*_*-S95-*	370	95mm ²	Set Screw
Cable Plug	CP*_*_*_*-S120-*	431	120mm ²	Set Screw
Cable Plug	CP*_*_*_*-S150-*	495	150mm ²	Set Screw
Cable Plug	CP*_*_*_*-C185-*	564	185mm ²	Crimped Contact
Cable Plug	CP*_*_*_*-C240-*	673	240mm ²	Crimped Contact
Cable Plug	CP*_*_*_*-C300-*	773	300mm ²	Crimped Contact

* = Key Position (Earth, Neutral, Line 1, Line 2, Line 3)

*** = Colour (Green, Blue, Brown, Black, Grey)

Reference Data for Cable Selection

The Current Rating of the connector is determined by the conductor size and type utilised.

For this publication, values are taken from IEE wiring regulations BS7671 Table 4F1A Reference Method 12 (Free Air). The quoted values relate to non-armoured Single Core, Copper stranded cables with Rubber Insulation and an operating temperature of 85°C.

Derating Data for 85°C for Rubber Insulated Cables

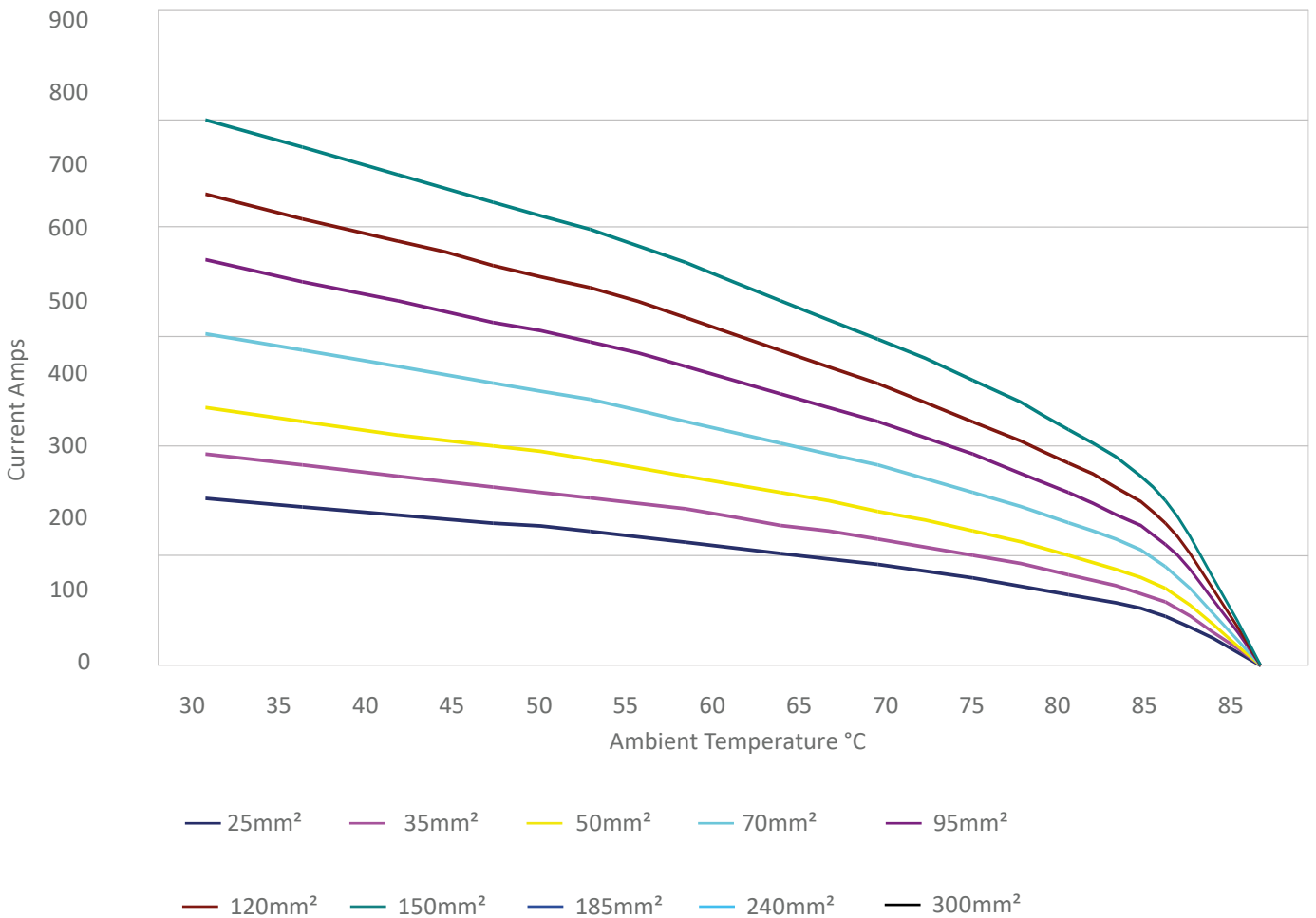

Powerline contacts are suitable for termination onto Aluminium conductors for short term applications. However, we recommend that bi-metallic contacts or cable lugs are used to provide optimum electrical and mechanical performance over time and repeated use.

Assembly Instruction Guide for Set Screw

1. Take contact and put screws to top as shown.

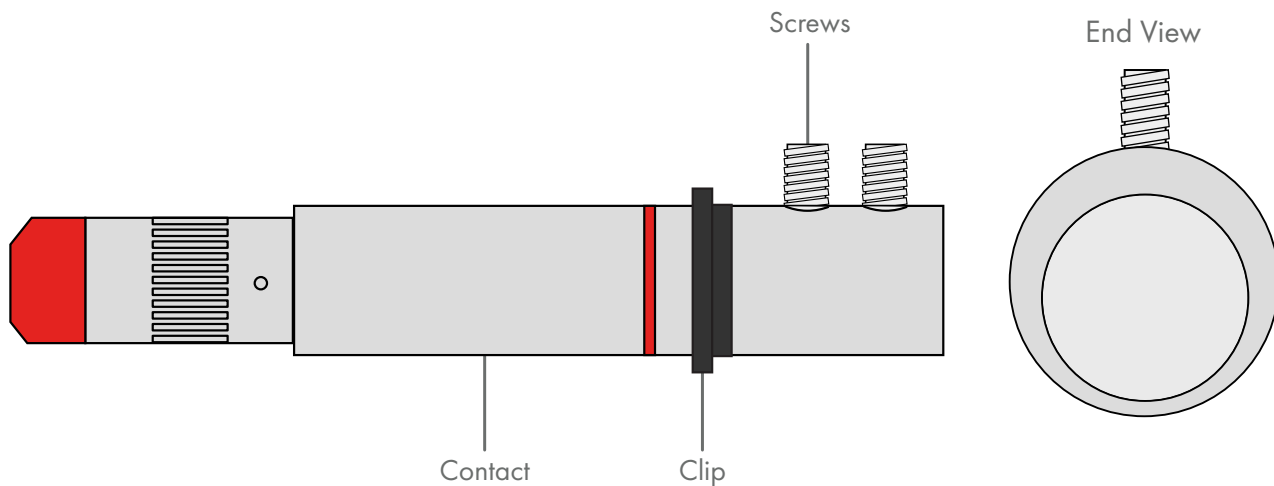

2. Fit cable gland and Backshell onto cable. Strip cable to length shown. Once stripped fit with appropriate reduction sleeve to match e.g. 50mm Cable uses a 120mm.

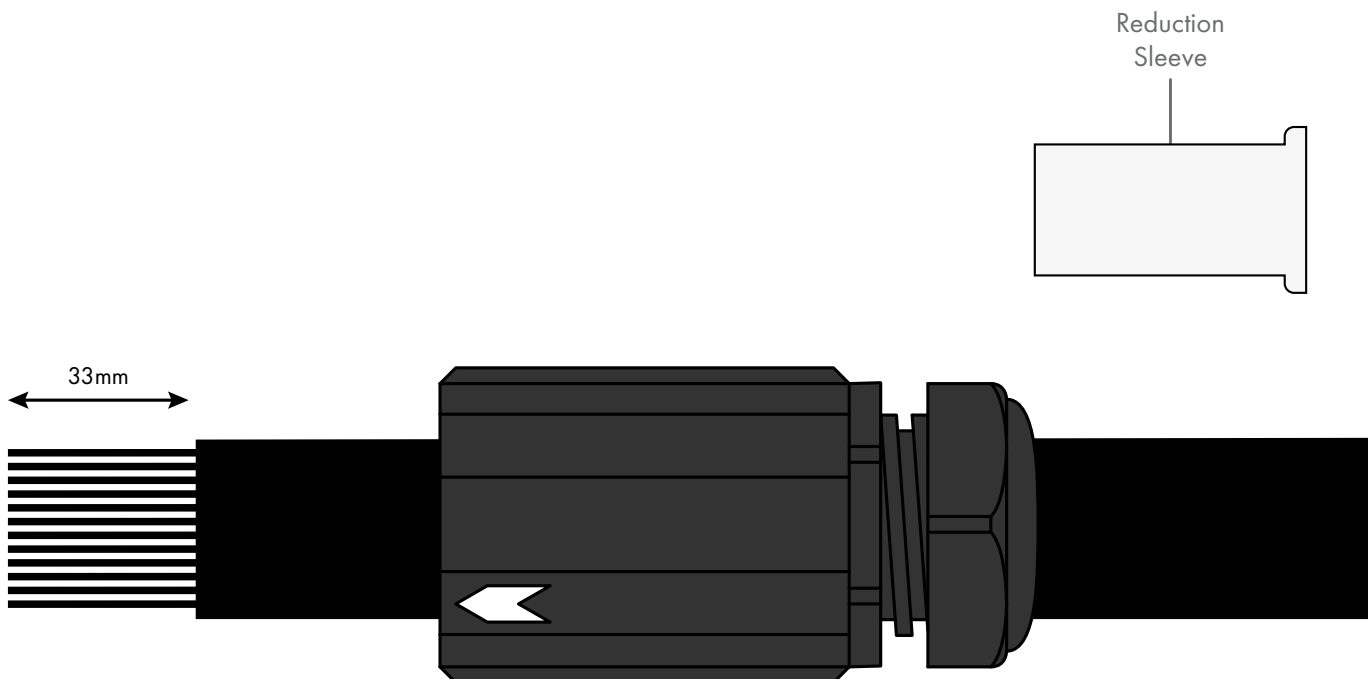

2. Continued.

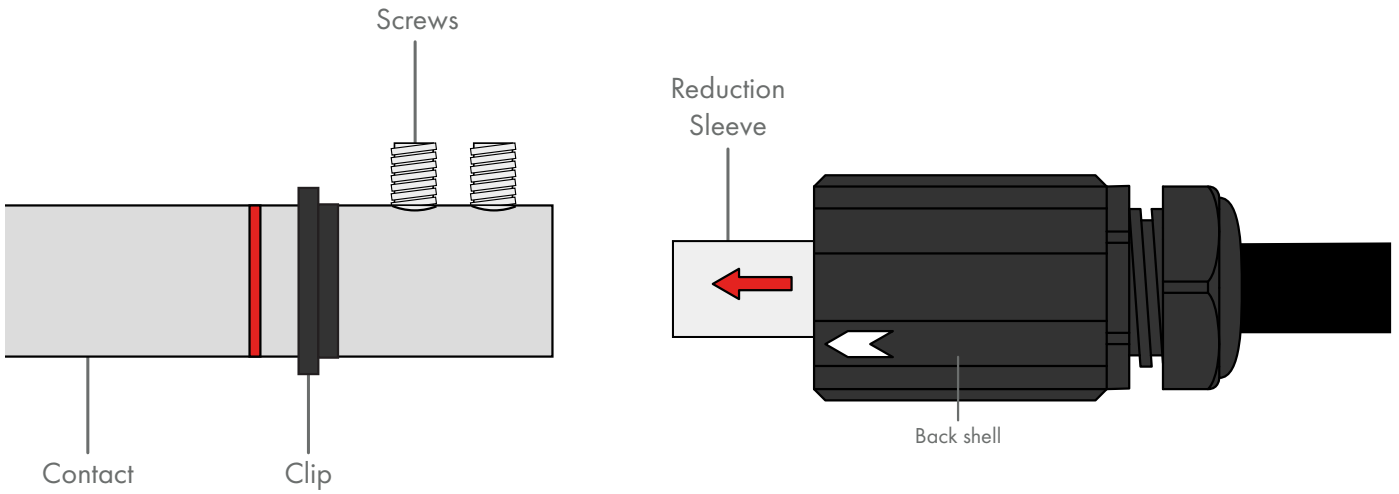

3. Torque screws to secure cable to contact to the recommended 12 N·m as required.

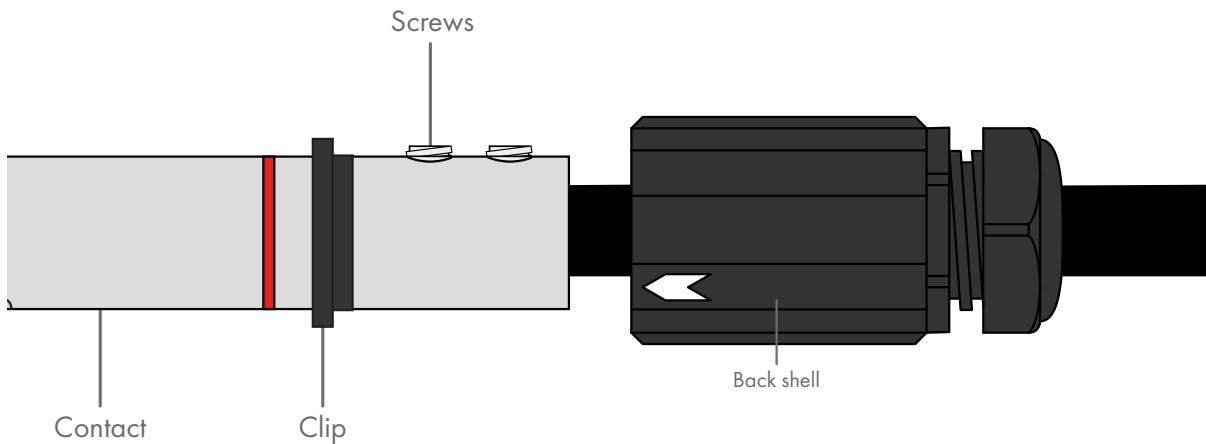

4. Slide back shell and cable gland down the cable, fully insert terminated contact into the front end. Please note, on male contact (as shown below) slotted keyway in contact must align with keyway in moulding. Not required on female line drain.

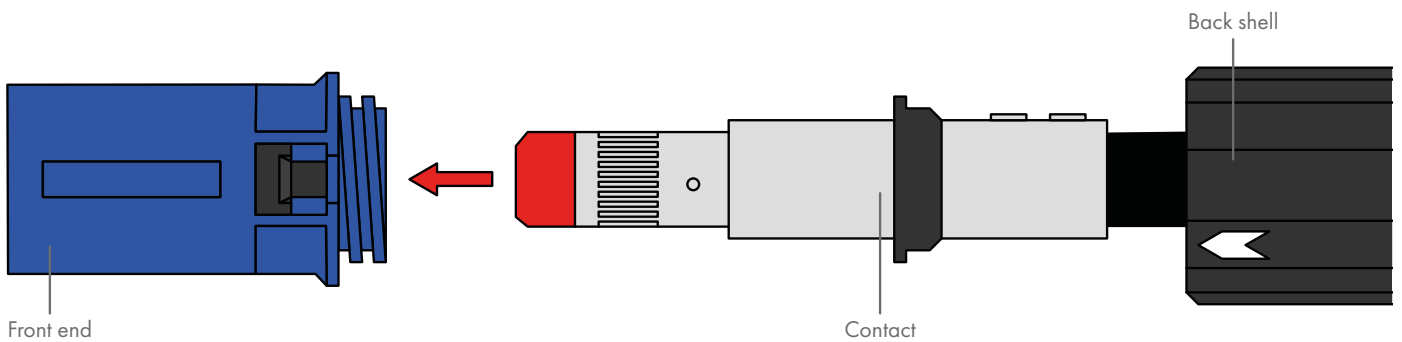

SOURCE (female moulding) only - DRAIN (male moulding) has no Keyway

5. Place the back shell over the contact to connect with front end.

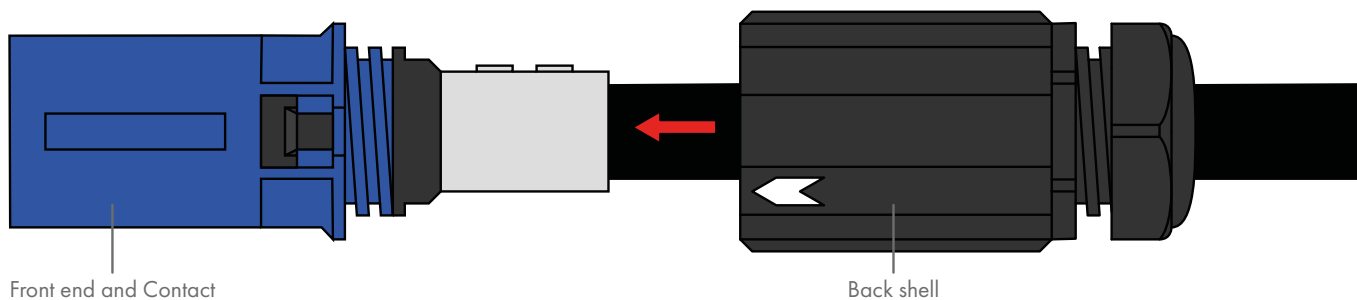

6. Turn back shell clockwise to screw into front end, making sure the arrow on back shell is lined up with front end locator pin.

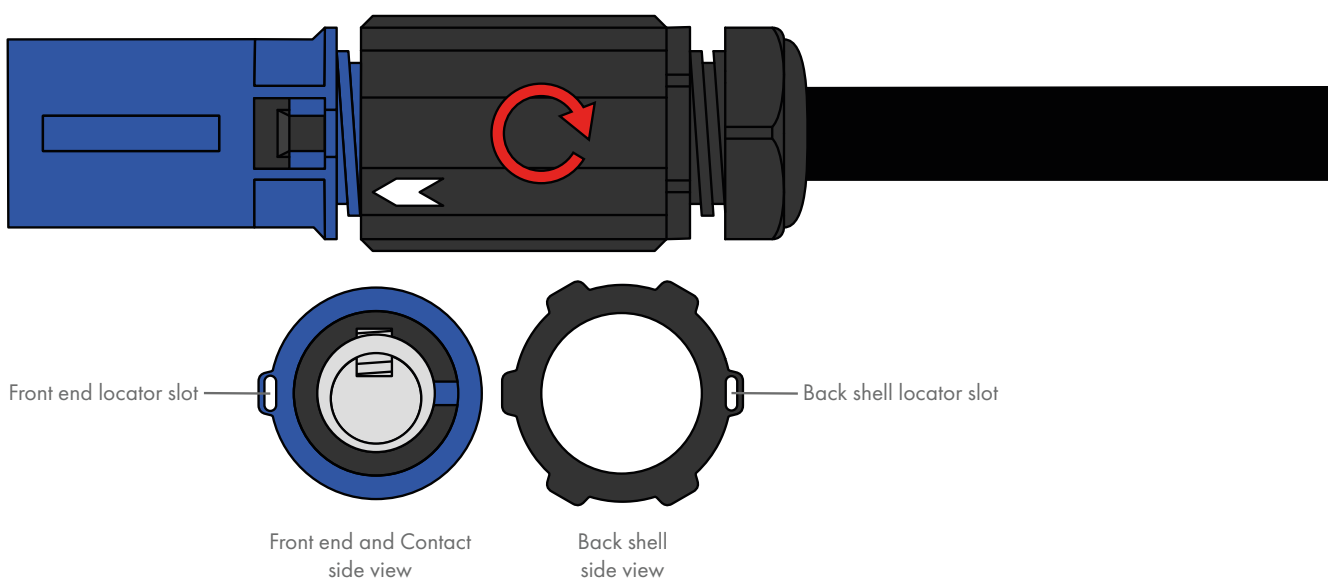

7. Slide locator pin up to make it secure.

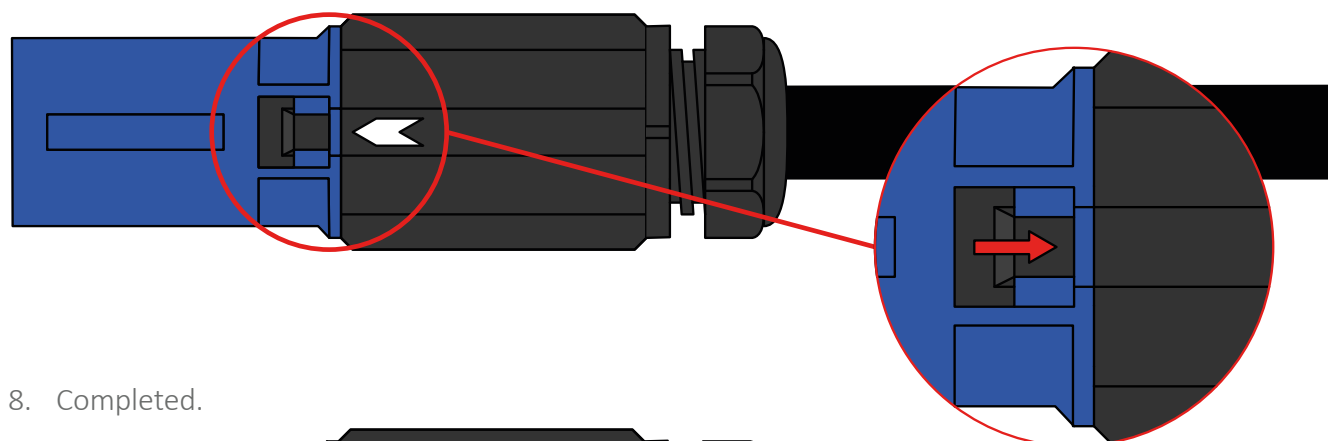

8. Completed.

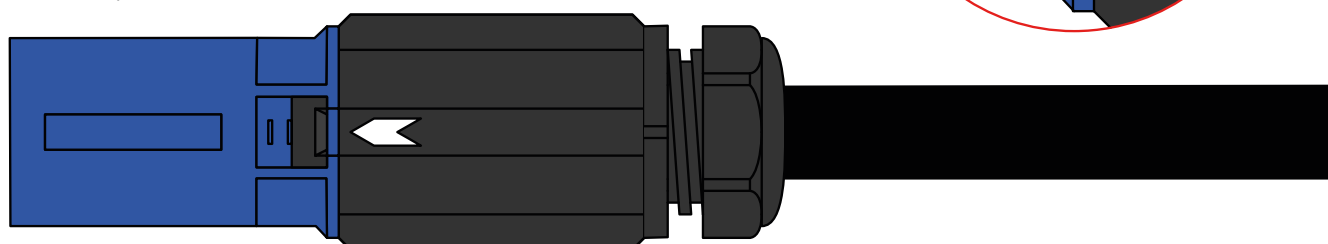

Assembly Instruction Guide for 240 and 300 Contacts

1. Remove packaging and remove contact from moulding.

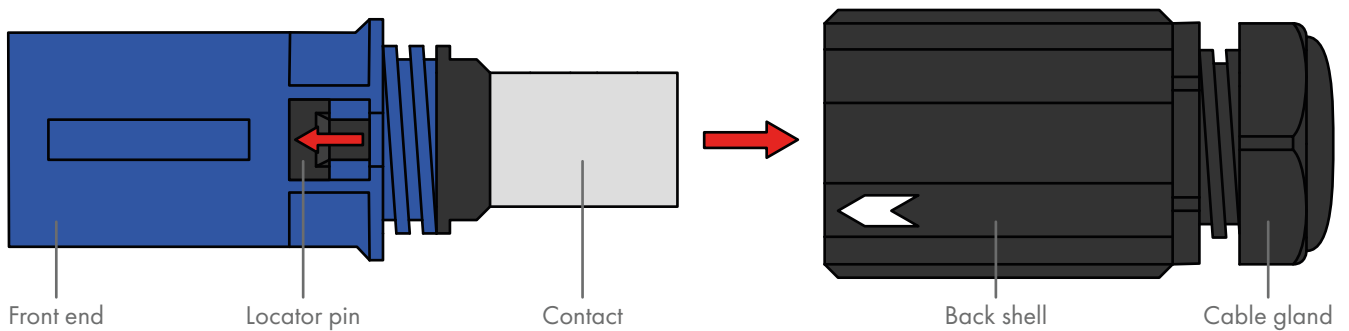

2. Strip cable as shown.



3. (a) Crimp **3 times** in positions shown using **CEMBRE DIES ME60-C**. Remove any excess flash using a file.

For 240 & 300 Contacts

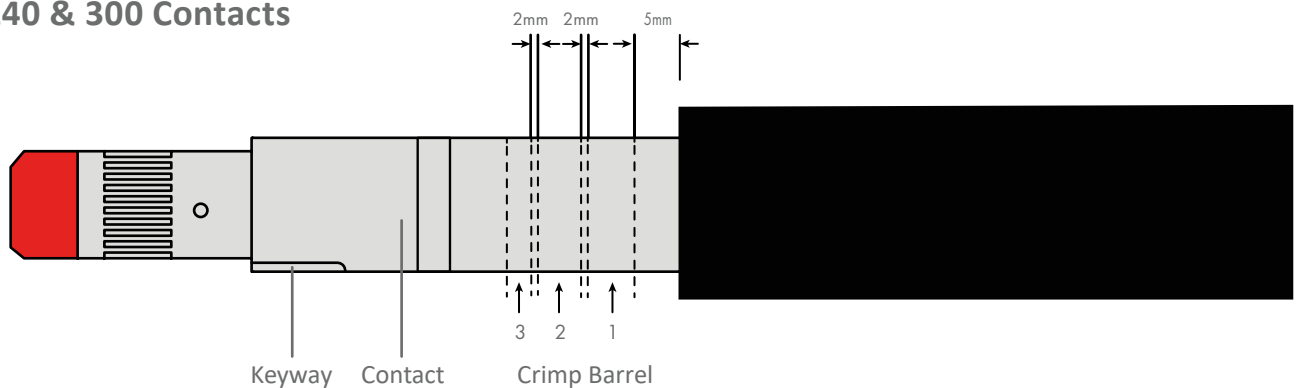

- (b) Crimp **once** in position shown using **CEMBRE DIES ME37-C**. Remove any excess flash using a file.

For 185 Contacts

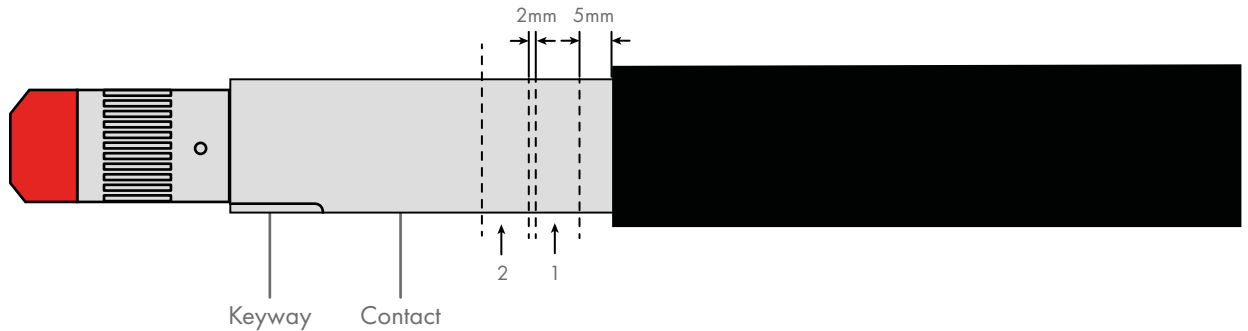

- To reassemble, fit back shell and cable gland down the cable. Press clip onto contact into the groove. Ensure clip is the correct way as shown. Fully insert terminated contact into the front end. Please note, on male contact (as shown below) slotted keyway in contact must align with keyway in moulding. Not required on female line drain.

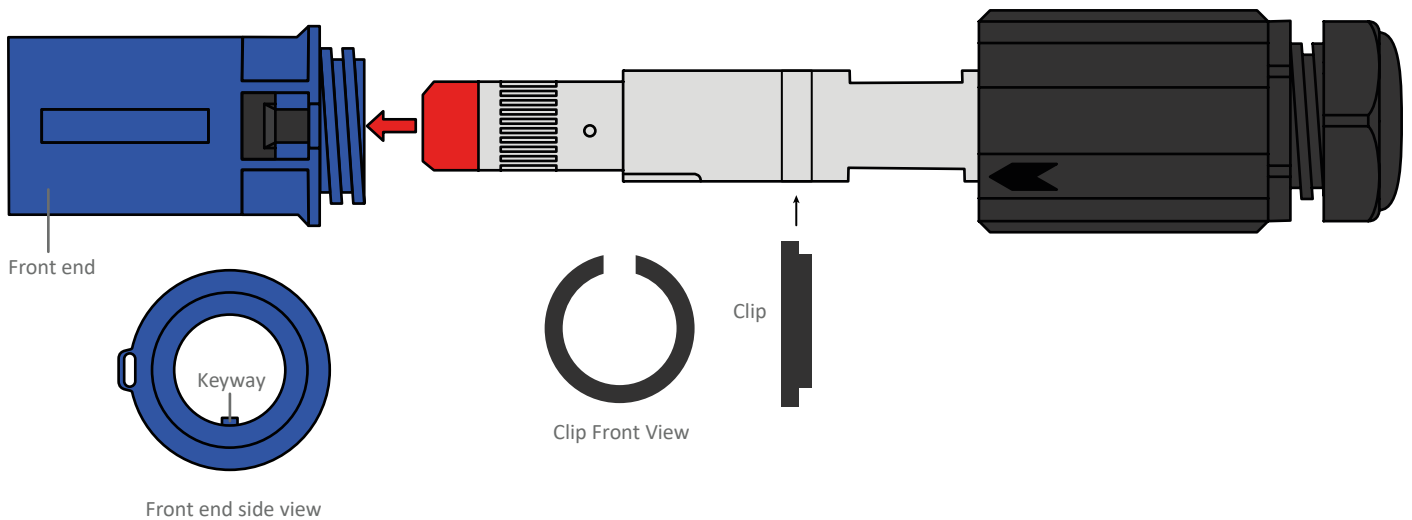

- Place the back shell over the contact to connect with front end.

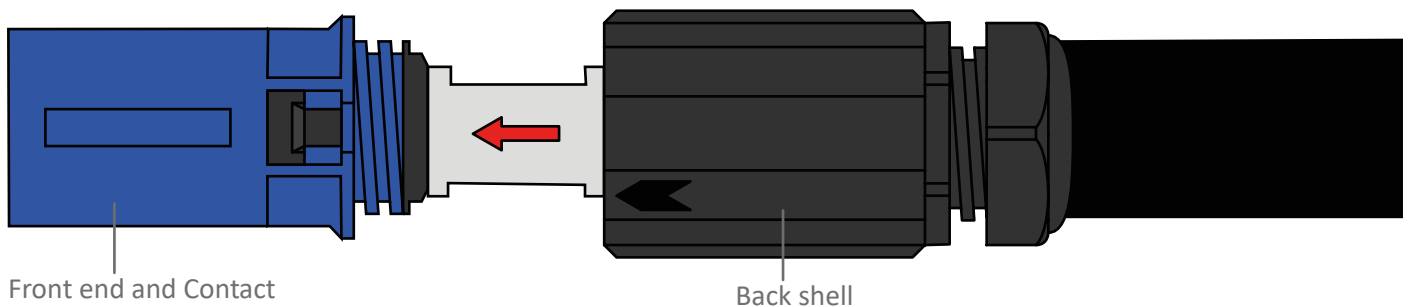

6. Turn back shell clockwise to screw into front end, making sure the arrow or company branding on back shell is lined up with front end locator pin.

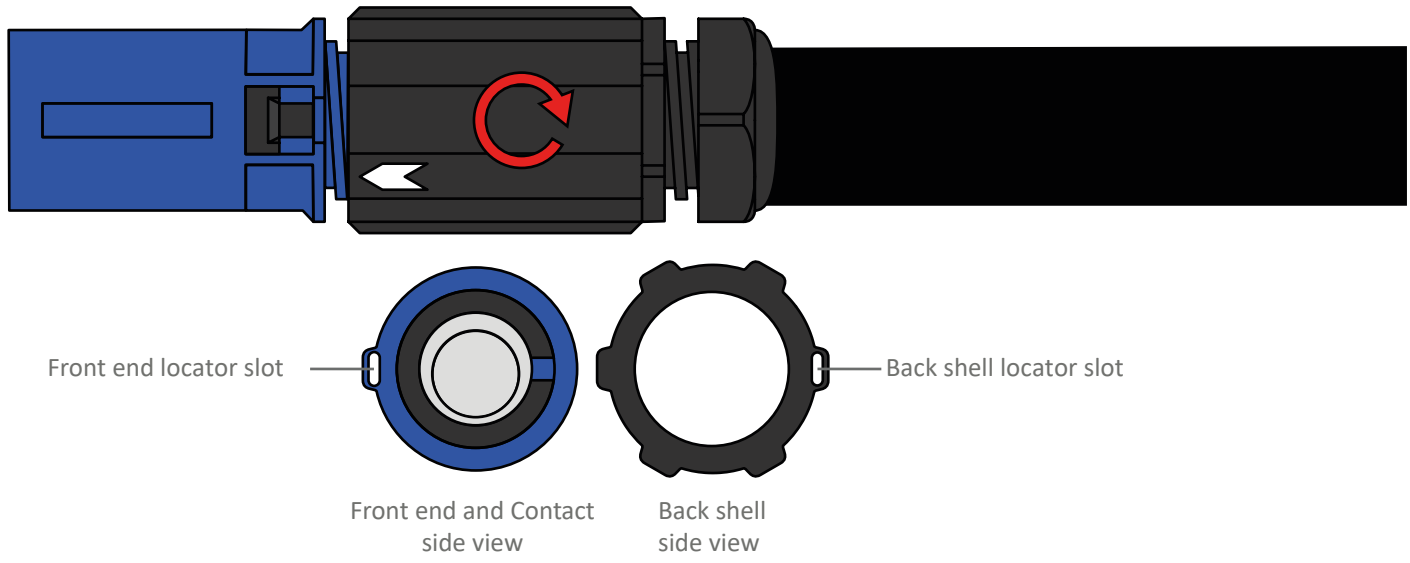

7. Slide locator pin up to make it secure. Tighten the cable gland onto cable.

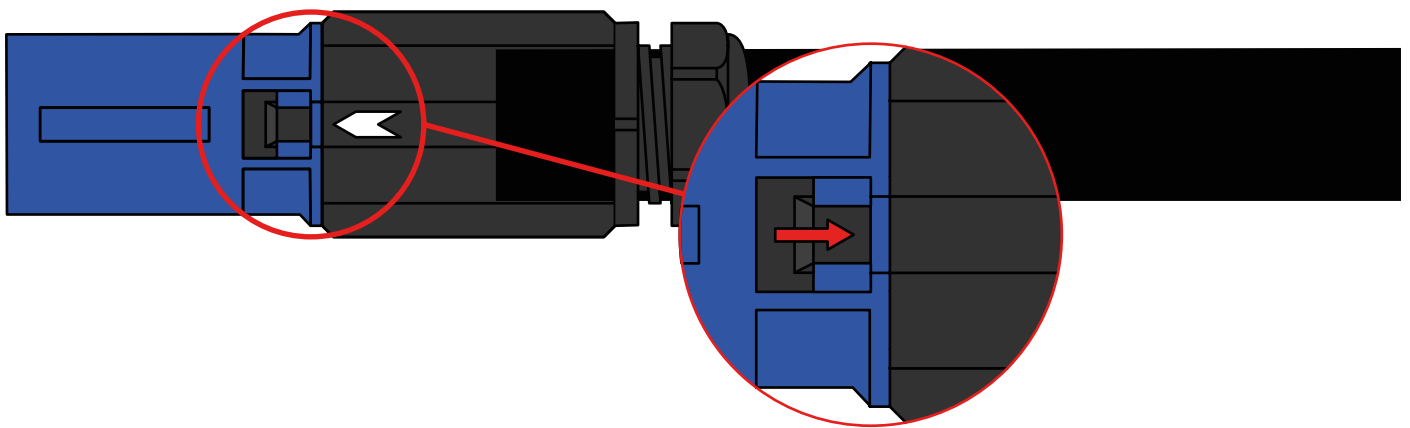

8. Completed.

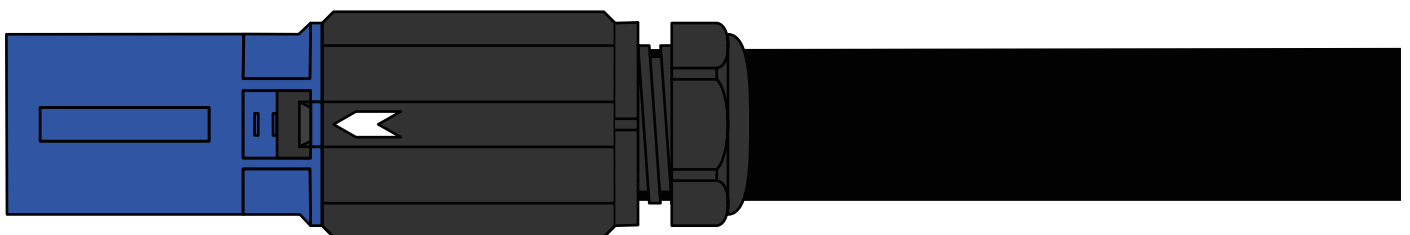

Disassembly Instruction Guide

1. Turn gland anti-clockwise to loosen.

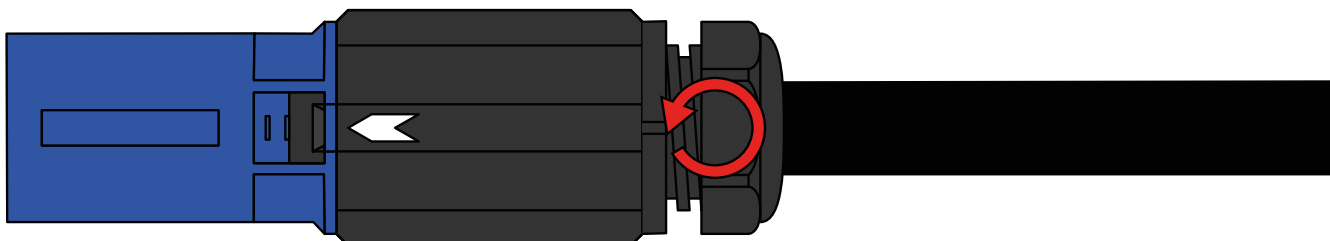

2. Unclip locator pin with small flat screwdriver.

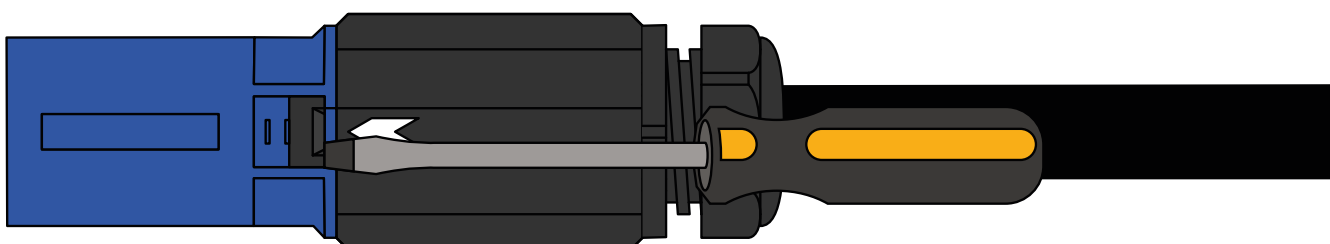

3. Slide locator pin down to unsecure it.

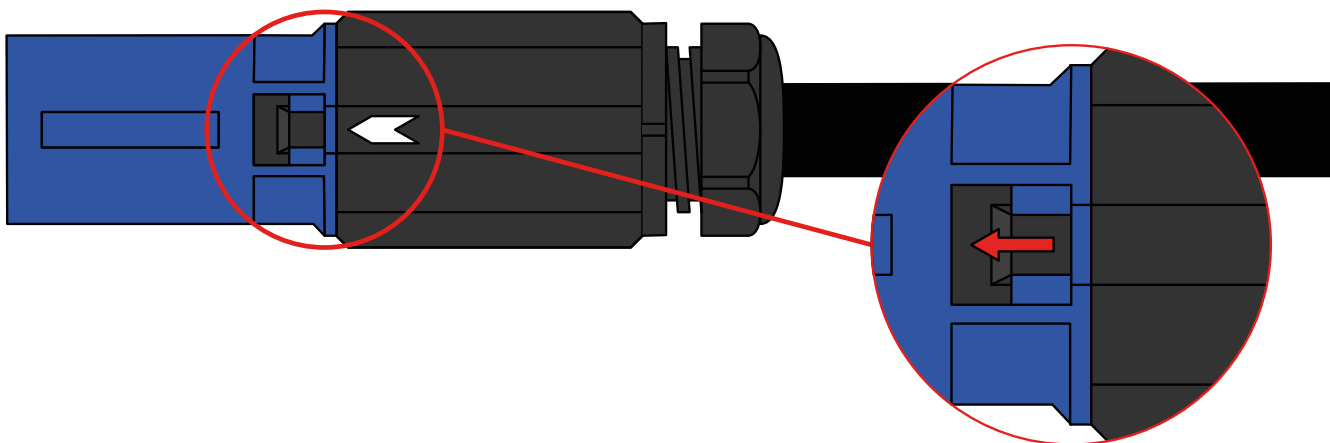

4. Turn back shell anti-clockwise to unscrew from front end.

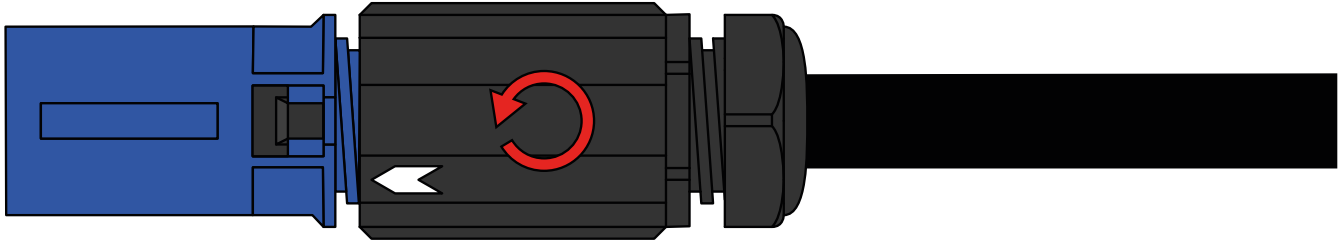

5. Remove front end from contact and slide back shell up the cable.

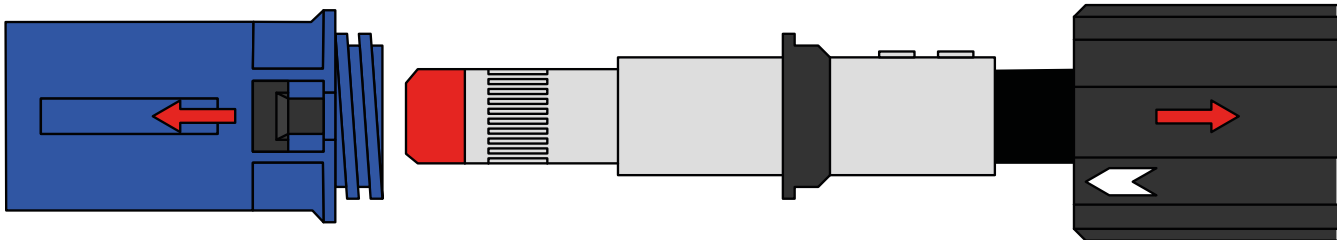

6. Completed.

Connector Release Key: REM-FL

To release a mated pair of connectors without the integrated locking key, we recommend the use of our REM-FL key. It is designed to push the secondary locking pin away from the locked position without any damage occurring to the Insulator.



Integrated Sliding Locking Pin



Fixed Locking Pin



Guide for Changing Locking Pin

Check orientation of locking pin is correct and carefully place the kit by lining up the two slots and insert into the moulding. (See figure 1 to figure 4.)

Figure 1



Figure 2



Figure 3



Figure 4



Place screw into the back of connector. Using 2.5mm Allen key, tighten screw. (See figure 5 and figure 6.)

Figure 5



Figure 6





Unit 2B Frances Industrial Park
Kirkcaldy, Scotland, UK
KY1 2XZ

Tel: +44 (0)1592 655725

Email: sales@ten47.com

www.ten47.com